

# EUROVENT 9/7



RECOMMENDED CODE OF PRACTICE  
TO KEEP YOUR COOLING SYSTEM  
EFFICIENT AND SAFE



# EUROVENT 9/7 - 2011

RECOMMENDED CODE OF PRACTICE  
TO KEEP YOUR COOLING SYSTEM EFFICIENT AND SAFE

Guidelines for the Prevention of  
Uncontrolled Bacteriological Contamination,  
including Legionella Pneumophila,  
in Cooling Towers and Evaporative Condensers

This code of practice is a revision of Eurovent Document 9/5 – 2002, developed by Eurovent Product Group 9 “Cooling Towers”. The major European manufacturers of evaporative cooling equipment are associated in the Eurovent PG9. The Product Group focuses on the environmental importance of efficient and safe heat rejection systems for which evaporative cooling technology provides effective solutions. The Group has prepared this code of practice on how to keep evaporative cooling systems safe. It is based on the status of knowledge available at the time of issue.

Published by EUROVENT  
80 bd Reyerslaan, 1030 Brussels

Responsible for this publication: Mrs Nina ION

[nina.ion@eurovent-association.eu](mailto:nina.ion@eurovent-association.eu)

Tel. 33 (0)1 49 96 69 80

Fax 33 (0)1 49 96 45 10

# Contents

|  |    |
|--|----|
| 1. Foreword.....   | 4  |
| 2. Scope.....  | 4  |
| 3. Definitions and Symbols .....   | 4  |
| 3.1. Definitions .....   | 4  |
| 3.2. Symbols .....   | 6  |
| 4. Normative References .....  | 7  |
| 5. Fundamentals .....  | 8  |
| 5.1. Evaporative Cooling.....  | 8  |
| 5.1.1. Evaporation & Blow-Down .....   | 8  |
| 5.1.2. Circulating Water Quality .....   | 9  |
| 5.1.3. Legionnaires' Disease .....   | 10 |
| 5.1.4. Chain of Events .....   | 10 |
| 5.1.5. Conditions that enhance Multiplication and Distribution of Legionella .....                           | 11 |
| 6. System Safety.....  | 12 |
| 6.1. Design Requirements .....   | 12 |
| 6.1.1. Product Design Recommendations, Access for Inspection, Maintenance and Cleaning.....                  | 12 |
| 6.1.2. Design of Cooling Towers without Water Stagnation .....   | 13 |
| 6.1.3. Drift Losses and Splash out.....  | 16 |
| 6.1.4. Accessory Design Recommendations (optional).....  | 18 |
| 6.1.5. System Design Recommendations.....  | 19 |
| 6.1.6. Specific System Requirements.....   | 20 |
| 6.2. Operational Recommendations.....  | 20 |
| 6.2.1. Mechanical Maintenance .....  | 20 |
| 6.2.2. Water Quality .....   | 24 |
| 6.2.3. Monitoring and Record Keeping .....   | 27 |
| 7. Personal Safety .....   | 27 |
| Personal Protection.....   | 27 |
| Annex: Typical contents of cooling system logbook.....   | 28 |
| Section 1: Owner Information .....   | 28 |
| Section 2: System Components.....  | 28 |
| Section 3: Subcontractors / Service Providers.....   | 28 |
| Section 4: Risk Analysis.....  | 28 |
| Section 5: Operating and Maintenance Plan.....   | 28 |
| Section 6: Data Logging and Record Keeping .....   | 28 |
| Section 7: Safety.....   | 29 |
| Section 8: Reports .....   | 29 |
| Attachment A: Typical Recommended Maintenance Schedule for Cooling Towers and<br>Evaporative Condensers..... | 29 |
| Attachment B: Tab Testing and Results .....  | 30 |
| Attachment C: Typical Quality Monitoring Checks .....  | 31 |
| Attachment D: Event Record Keeping .....   | 32 |

## 1. Foreword

Evaporative cooling is an efficient and cost effective means of removing heat from air conditioning, refrigeration and industrial process cooling systems, based on a natural principle by making use of adiabatic cooling with or without latent heat transfer.

Evaporative cooling combines high thermal efficiency and cost effectiveness by achieving low cooling temperatures with minimum energy and water usage. Low cooling temperatures are essential for many processes to achieve high system efficiency.

## 2. Scope

The purpose of this standard is to describe the measures that should be undertaken to achieve efficient operation of evaporative cooling installations and to control the risk of Legionnaires Disease outbreaks. The measures described here apply to system designers, installers and operators as well as to the manufacturers of evaporative cooling equipment. Evaporative cooling installations are installations in which water is exposed to an air stream with the aim to enhance the cooling process either by humidification of the air only or by combination of air humidification and latent heat transfer.

This standard provides recommendations and defines face values. National or regional requirements, which differ from these recommendations, must be adhered to first.

## 3. Definitions and Symbols

### 3.1. Definitions

Adiabatic Coolers: Equipment used to transfer heat from a process to the atmosphere by lowering the temperature of the entering air by humidification, with constant enthalpy.

Aerosol: Fine water droplets entrained in an air stream.

Air Inlet Louvers: Devices installed at the air inlet to minimize splash-out and exposure of the basin water and heat transfer media to sunlight.

Automatic Blow-down: Determined as a function of heat load keeping the concentration factor between acceptable limits.

Backflush Water: Water used to flush a filter and thereafter removed from the system.

Biofilm: Organic deposits inside the cooling system.

Blow-down: Water discharged from the system to control the concentration of salts or other impurities in the circulating water.

Closed Circuit Cooling Tower: Equipment in which the process fluid circulates inside a heat exchanger which is cooled by water circulating in direct contact with air. The heat exchanger may be inside or close-coupled outside the cooling tower.

Constant Blow-down: Blow-down achieved by a fixed setting of a metering valve in the blow-down piping. The amount of blow-down is independent from the heat load (evaporation loss).

Counterflow: Where air flows in a counter current to the water flow within the evaporative cooling device.

Crossflow: Where air flows perpendicularly to the water flow within the evaporative cooling device.

Cycles of Concentration: Ratio of the concentration of elements in the circulating water compared to the concentration in the makeup water.

Dampers (Discharge): Modulating airfoil blades installed at the air discharge of the evaporative cooling device with the aim to reduce air flow or heat loss at standstill conditions.

Dead Legs: Areas in the water piping through which the water is not circulated.

Dissolved Solids: Inorganic and organic matter in true solution. Usually expressed as mg/l or ppm.

Drift Eliminator: The assemblies downstream of the heat transfer media which serve to reduce drift loss.

Drift Losses: The portion of the water flow rate lost from the device in form of droplets mechanically entrained in the discharge air stream, commonly expressed as a percentage of the circulating water flow rate. It is independent of water lost by evaporation.

Equalizing Lines: Connecting pipes between multiple cooling tower cells operating in parallel with the aim to establish a common operating water level in all cells. Usually required only with open cooling towers.

Evaporation Loss: The amount of water evaporated into the atmosphere during the heat transfer process.

Evaporative Cooling Equipment: Heat transfer equipment using the evaporation of water to enhance or accomplish the transfer of heat from a process to the atmosphere.

Evaporative Cooling Installations: Installations in which water is exposed to an air stream with the aim to enhance the cooling process either by humidification of the air only or by combination of air humidification and latent heat transfer.

Fouling: Deposit of suspended solids inside the installation in combination with biological activity.

Galvanic Corrosion: Corrosion caused by the difference in electrochemical tension of different materials in direct or close contact in a humid environment.

Hybrid Cooling Tower: Apparatus incorporating two modes of heat transfer operating simultaneously, wet and dry with the aim to reduce water consumption and/or to reduce or eliminate the visibility of the plume. Hybrid cooling towers can be of the open- or closed-circuit type.

Inspection Points: Locations within or at the evaporative cooling device, which must be accessible for visual inspection.

Legionella Pneumophila: The most virulent Legionella bacteria causing Legionnaire's disease, which is a rare and severe form of pneumonia.

Legionella Species (LS): All types of legionella bacteria together, generally expressed in cfu/l.

Legionnaire's Disease: A rare but serious form of pneumonia: disease caused by Legionella Pneumophila.

LS Concentration: Concentration of Legionella species, usually expressed in cfu/l.

Maintenance Points: Locations within or at the evaporative cooling device requiring maintenance. Sufficient access to these points to carry out the requested maintenance procedure must be assured.

Make-up Water: The water added to the system to replace water lost by evaporation and blow-down, as well as drift, leakage and splash-out losses.

Once-through System: Heat exchange system in which the cooling water is not re-circulated.

Open Cooling Tower: Apparatus wherein the process fluid is warm water which is cooled by the transfer of mass and heat through direct contact with atmospheric air.

Plume Abatement Coils: Finned coils integrated into the evaporative cooling device with the aim to reduce or eliminate visible plume by warming part or all of the discharge air moved through the device. Plume abatement coils can be integrated into the process fluid cycle or fed by external heat sources.

Risk Analysis: Analysis combining the frequency of a potentially occurring incident and its severity and the prevention thereof.

Scaling: Deposit of oversaturated dissolved solids (Calcium Carbonate scaling is the most common one).

Splash-out: Droplets ejected outside the cooling tower through the air inlets, due to wind turbulences or when the fans are stopped.

Start-up: Start of the system with water after a period of shutdown.

Total Aerobic Bacteria (TAB): Concentration of aerobic bacteria in water, usually expressed as cfu/ml.

Visible Plume: The discharge air stream of the device when it becomes visible (wholly or in part) by the condensation of water vapour as the moist air stream is cooled to the ambient temperature.

Water Distribution (System): System for receiving the water entering the device and distributing it over the area where it contacts the air.

Water Treatment Programme or System: Everything done to the circulating water to control scaling, corrosion and fouling. It must be adapted to the actual water quality which varies with location and time. It may include filtration, chemical and/or biocide additives, physical treatment,

## **3.2. Symbols**

TAB: Total aerobic bacteria

cfu/ml: Unit of bacterial count: Colonies formed unit per millilitre of water

LS: Legionella species

cfu/l: Unit of Legionella count: colonies formed unit per litre of water

## 4. Normative References

1. EUROVENT 9/5 Recommended Code of Practice to keep your cooling system efficient and safe.
2. Dr. A. Olkis, Mikrobiologische Kontrolle in Rückkühlsystemen, 6. VDMA-Kühlturmtagung, 2003.
3. Aqua Nederland: Legionella-bestrijding in koel - en proceswater.
4. Legionella et tours aéroréfrigérantes, guide des bonnes pratiques.
5. MSC: Legionnaires' Disease – the control of Legionella bacteria in water systems.
6. Ministerie van de Vlaamse Gemeenschap: Voorkom Legionella
7. Ondeo-Nalco: European Good Practice Guide
8. KIWA: Omvang en preventie van vermeerdering van legionella in koeltorens en luchtbehandelingsapparaturen.
9. The Water Management Society: Keeping your cooling tower safe.
10. Expert Verlag: Legionellen – ein aktuelles Problem der Sanitärhygiene.
11. ASHRAE Guideline 12-2000: Minimizing the risk of Legionellosis associated with building water systems.
12. CTI: Legionellosis Guideline – Best Practices for Control of Legionella.
13. European Commission – IPPC Bureau: Reference document on the application of best available techniques for industrial cooling systems.
14. ARBO informatie A1-32
15. DIN-Taschenbuch 255, Instandhaltung Gebäudetechnik – Normen, Technische Regeln.
16. Omvang en preventie van vermeerdering van Legionella in Koeltorens en luchtbehandelings-apparaturen KWA/KIWA NL.
17. Control of microbial growth in air handling and water systems of buildings SAA/SNZ.
18. VDI 6022: Hygienic standards for ventilation and air conditioning systems.
19. Legionnaires' Disease, The control of Legionella bacteria in water systems, Health and Safety Commission U.K.

## 5. Fundamentals

### 5.1. Evaporative Cooling

Evaporative cooling can be applied in a large number of different products, such as open cooling towers, closed-circuit cooling towers, hybrid cooling towers (open or closed) or adiabatic coolers. In all of these applications water is subjected to an air stream, hence creating an aerosol either directly through the exposure of spray water to the air stream or indirectly through the impact of the air stream on water, which has accumulated on the construction inside or outside the heat transfer equipment. In some evaporative cooling products, such as open cooling towers or closed circuit cooling towers water is typically circulated. Although these products can also be used in once-through systems, in this document they are referred to as evaporative products with circulating water loops. For such products care must be taken to avoid excessive accumulation of dissolved solids. In some hybrid cooling towers and adiabatic coolers, water is only used to humidify the air and in certain designs it is aimed to achieve this without recirculation of the spray water. In this document these products are referred to as evaporative products without circulating water loops. Also in these applications care must be taken to operate with the right water quality. Regardless the fact whether the spray water is re-circulated or not, the recommendations with regard to the control of microbiological growth made in this standard must be adhered to.

#### 5.1.1. Evaporation & Blow-Down

In evaporative cooling equipment with circulating water loop the cooling is accomplished by evaporating a small portion of this water as it flows through the unit. When the water evaporates, the impurities originally present in the water remain. Unless a small amount of water is drained from the system, known as blow-down, the concentration of dissolved solids will increase rapidly and lead to scale formation or corrosion or both. Also, since water is being lost from the system through evaporation and blow-down, this water needs to be replenished.

The total amount of replenishment, known as make-up, is defined as:

$$\textit{Make-up} = \textit{evaporation loss} + \textit{blow-down}$$

The evaporation loss depends on a variety of factors, such as mass flow ratio air to water, climatic conditions and the heat rejection achieved. For this reason an easy way to calculate the evaporation loss on an annual base is not available. The general formula is 0.44 litres of water evaporation per 1000 kJoule of heat rejection is based on summer conditions with dry air and should only be used to estimate the evaporation loss at design conditions. This simplified formula is not suitable to calculate evaporation losses year round.

The amount of blow-down is determined by the design cycles of concentration for the system. These cycles of concentration depend on the quality of the make-up water and the design guidelines for the quality of the re-circulating water. Depending on the materials of construction of the system the water quality guidelines may differ and the system designer or manufacturer's instructions must be adhered to in this regard.

Cycles of concentration are the ratio of the dissolved solids concentration in the re-circulating water compared to the dissolved solids concentration in the make-up water. Once the design cycles of concentration have been defined, the blow-down rate can be calculated.

The cycle of concentration is related to the water quality and the water treatment programme. It must be limited to a certain value to avoid undesirable scaling and/ or corrosion. As a general rule it is recommended that the design cycles of concentration should not exceed 5. Above 5 the water savings through smaller amounts of blow-down become less and less significant.

Increased cycles of concentration reduces the water contamination but go hand in hand with a high operating risk, as any loss of control quickly leads to undesirable scaling or corrosion within the system.

### **5.1.2. Circulating Water Quality**

In addition to impurities present in the make-up water, any airborne impurities or biological matter are carried into the tower and drawn into the re-circulating water. Over and above the necessity to continuously bleed off a small quantity of water, a water treatment programme specifically designed to address scale, corrosion and biological control should be initiated when the system is first installed and maintained on a continuous basis thereafter. Moreover there must be an ongoing programme of monitoring in place to ensure that the water treatment system is maintaining the water quality within the control guidelines.

The incoming make-up water will normally have a tendency to be either corrosive or scale forming and this will also be influenced by the water temperature and the cycles of concentration. Steps must be taken to prevent both corrosion and scale formation.

#### *a) Scale Formation*

Excessive scaling on the heat transfer surfaces within an evaporative cooling product greatly reduces heat transfer efficiency and could even destroy its structure. This can result in higher cooling temperatures than design and eventually system down-time. Scale formation always causes higher energy consumption, and this applies all year round regardless of the load on the system. Whilst scale itself is not considered as a nutrient for bacteriological growth, heavy scale formation provides a breeding haven for micro-organisms and can therefore add to the risk of bacteriological contamination.

Depending on the main supply water and system operation, scale formation can be prevented by the correct combination of softening of the make-up water, control of pH and bleed-off and dosing of scale inhibitor chemicals. Physical methods for controlling scale such as electro-magnetic or ultrasonic techniques and others are also available. The control of scale needs to be carefully evaluated on a case-by-case basis.

Scale formation is independent of the materials of construction of the system components therefore it needs to be a clear objective to avoid scale formation in the first place.

#### *b) Corrosion*

Premature or rapid corrosion is detrimental to the cooling system components and may shorten equipment life considerably. Corrosion by-products, such as iron oxides, can furthermore encourage bacteriological growth. For these reasons corrosion within a cooling system should be minimised at all times. To achieve this, the water quality must be kept within the limits specified by the supplier of system components and, in many cases the dosing of a chemical corrosion inhibitor as well as the control of the pH value is recommended.

*Note: Due to advances in chemical blending most water treatment chemical suppliers offer a corrosion and scale inhibitor as a single chemical.*

c) Biocidal Control

Proper operation, blow-down and chemical water treatment for scale and corrosion are not a guarantee of controlling bacteriological growth in a cooling system. Therefore specific attention must be given to the matter of bacteriological control. Not only can bacteriological growth reduce heat transfer efficiency by formation of slimes or biofilms but, more importantly, proliferation of bacteria can sufficiently contaminate the re-circulating water that it becomes a potential health hazard. Amongst the harmful bacteria the most important in this context is Legionella Pneumophila which in uncontrolled conditions, could result in cases of Legionnaire's Disease.

There is a wide range of systems, which allow controlling the microbiological growth (including Legionella). A water treatment specialist should advise on the best biocidal treatment for a particular cooling system.

d) Fouling

Fouling of heat exchange surfaces due to dirt, sludge and slimes in the system will not only affect thermal performance, but may also encourage the growth of bacteria. In open cooling towers, for example, it may even destroy the fill pack. Therefore steps must be taken to avoid a build up of dirt and debris within the cooling tower and the rest of the system.

For systems with dirty water or where significant amounts of airborne dirt and debris are carried into the system, filtration of the re-circulating water may be needed. Usually this is side stream type where a portion of the water is drawn from a water collection basin, filtered and then returned to the system.

Sometimes silt and sludge can be controlled with chemical biodispersants, which are either dosed separately or blended with a chemical biocide.

### **5.1.3. Legionnaires' Disease**

Legionnaires' Disease is an uncommon but serious form of pneumonia. It affects only a small percentage of people who are susceptible to an infection of this kind. It can only be contracted by inhaling contaminated aerosols. It cannot be contracted by drinking contaminated water.

Legionella, the bacteria, which causes the disease, is commonly found in surface water such as ponds and rivers. Only some species of the bacteria, such as Legionella Pneumophila, can become harmful to humans. It is likely to exist in low concentration in most water systems. In such concentrations the bacteria is harmless. It requires an improbable and avoidable chain of events to cause people to be infected with Legionella bacteria.

### **5.1.4. Chain of Events**

An outbreak of Legionnaires' Disease associated with evaporative cooling equipment requires a 'Chain of Events' with ALL EVENTS in the chain LINKED together and occurring in sequence.

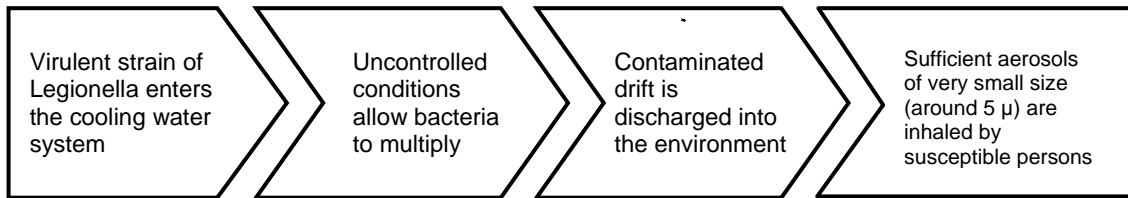

To effectively prevent the risk of Legionnaires' Disease, it is necessary to influence this chain of events at any link. There are three chain links, which can be influenced by good design and correct operation of the cooling system:

- a) prevent conditions that encourage multiplication of bacteria
- b) minimise drift or aerosol effect in the discharge air stream
- c) reduce chances of inhalation by people through equipment location and/or personal protection.

The measures mentioned above are not equally effective in terms of prevention. By far the most important measure is to prevent uncontrolled conditions that allow the bacteria to multiply.

### 5.1.5. Conditions that enhance Multiplication and Distribution of Legionella

If a virulent strain of Legionella enters the cooling system, a number of factors dictate whether multiplication can occur. To become harmful Legionella bacteria, particularly the species which affect humans, must proliferate in an uncontrolled manner in the re-circulating water. Typically concentrations of total aerobic bacteria up to 10.000 cfu/ml mean the system is under control but concentrations of more than 100.000 cfu/ml require immediate corrective actions to reduce the bacterial level. If the concentration of the Legionella species is measured separately, it must not be higher than 1000 cfu/l. If this concentration is exceeded, corrective action must be taken.

Testing of Legionella should be done according to recognised standards. The following conditions can lead to high concentrations of Legionella:

#### a) Temperature

Below 20°C the bacteria do not multiply (but will still survive). The maximum growth rate is at a temperature of 37°C. This is the temperature range typically found in evaporative cooling applications.

#### b) Nutrients

For growth to occur nutrients for Legionella multiplication must exist in the cooling system. Typical nutrients are sediments, sludge, corrosion debris and materials, such as untreated wood and natural rubber, which support microbiological growth. Algae, slimes and fungi also provide nutrients for Legionella multiplication.

#### c) Havens

Biofilms, slimes and scale can provide a haven for the growth of Legionella.

Regular inspection and, if required, cleaning and disinfection are needed to minimise these within the cooling system.

#### d) Aerosols

Evaporative cooling by its design involves close contact between water and air and droplets of water become entrained in the air stream. However not all of the

water entrained in the air is potentially harmful. Plume from, for example, cooling towers and evaporative condensers is often mistakenly considered as environmental pollution. Plume occurs when warm air discharging from the cooling tower condenses upon contact with colder ambient air. However this is pure water vapour and does not contain bacteria.

On the other hand water droplets that are entrained in the air stream and carried outside the equipment as drift loss or splash out could be harmful if they are contaminated with Legionella bacteria.

Measures must be taken to minimise the amount of droplets that can escape from evaporative cooling equipment.

Whilst the efficient reduction of drift loss and splash out may help to reduce risk, it cannot be viewed as a “stand alone” preventive measure.

Evaporative cooling equipment is only a part of a cooling system and to control the risk of Legionnaires Disease requires therefore a look at the total cooling system in as far as it is directly connected to the water fed to the evaporative heat exchanger. System safety is not only a matter of correct selection and installation of components for the heat rejection, but also involves water and biocide treatment, a proper assessment of risks, as well as a plan, which describes the operation of the cooling system in function of the process to be cooled. Finally the evaporative cooling equipment itself should meet certain design requirements, in which case the operation risk is further reduced.

## 6. System Safety

### 6.1. Design Requirements

#### 6.1.1. Product Design Recommendations, Access for Inspection, Maintenance and Cleaning

##### Inspection and Maintenance

It is important that access is provided to the areas listed below, requiring regular inspections and maintenance:

- drift eliminators
- water distribution systems
- bearings and drives
- air inlet louvers
- electrical equipment
- cold water basins (if applicable)
- strainers, valves (if applicable)
- controls requiring settings and/ or regular adjustments
- heat transfer section
- Sound baffles
- Bleed off nipples

For this purpose the equipment shall have an appropriate amount of adequately sized access doors or hatches.

Access openings dimensions: minimum section should be 500 X 500 mm, or minimal diameter 600 mm (ie identical to the section of 500X 500). Whenever hatches are smaller, the length of the cooling tower must be considered in

2.5 m sections, and each section should have one opening having a minimum diameter of 500 mm, or have a section of 450 x 450 mm.

If the interior of the equipment is large enough to be entered by people, sufficient access doors or hatches are required. Where the use of access doors or hatches is not possible access can be provided by the removal of certain parts of the enclosure, for example eliminators, as per the manufacturer's operating manual.

If the equipment is supplied with accessories, such as air intake or discharge ducts or sound attenuators, these components must be equipped with adequate access in order to avoid any obstruction to the access to the maintenance and inspection points listed above. For larger equipment and depending on the location of the interior maintenance and inspection points, interior walkways and or ladders can be provided.

Depending on site conditions it also may be necessary to install ladders, safety cages, stairways, access platforms, handrails and toeboards for the safety and convenience of the authorised service and maintenance personnel. The need for such external access provisions is usually determined by the installer of the equipment.

#### Access for Cleaning

The design of most evaporative cooling products usually does not permit mechanical cleaning of the entire interior, but mechanical cleaning of the cold water basin (if applicable), where the largest amount of sludge and dirt accumulates, should be possible. Unless the access provisions for inspections and maintenance already provide sufficient access to the cold water basin, additional access provisions must be made to allow access to the cold water basin. This can be achieved by removable access doors or hatches or removable air inlet louvers depending on the product design. The cold water basin design should be so that it permits easy flushing to one or more central points and for this purpose it is recommended to apply a sloping basin bottom design where possible. Components installed in the basin, such as strainers or strainer hoods, should be accessible or removable so that proper mechanical cleaning be possible.

To allow the complete drain of the basin with one or more drain holes, it is recommended that the cold water basin should have a minimum 1 % slope over 60 % of the whole basin surface; the slope direction must not be opposed neither to the drain flow direction nor to the main cold water outlet. The drain hole(s) must be located at the lower part of the basin.

Large basins should be equipped with interior ladders to facilitate access by maintenance and service personnel. In addition to the cold water basin, mechanical cleaning of the water distribution system should be possible. For this reason, nozzles should preferably be of the removable type. Areas of the equipment, which are not accessible for mechanical cleaning should at least be designed such, that flushing, chemical cleaning and disinfection, be possible.

### **6.1.2. Design of Cooling Towers without Water Stagnation**

#### Tower Casing

The tower casing should avoid water stagnation. For this reason, basins and walls should not have a slope on the opposite direction of the water flow direction. Basins shall have a drain connection or hole to allow proper drainage.

## Pipes connected to the Cooling Tower

The piping should preferably have no point below the basin, but must be self-drainable or drainable.

*Example pump:*

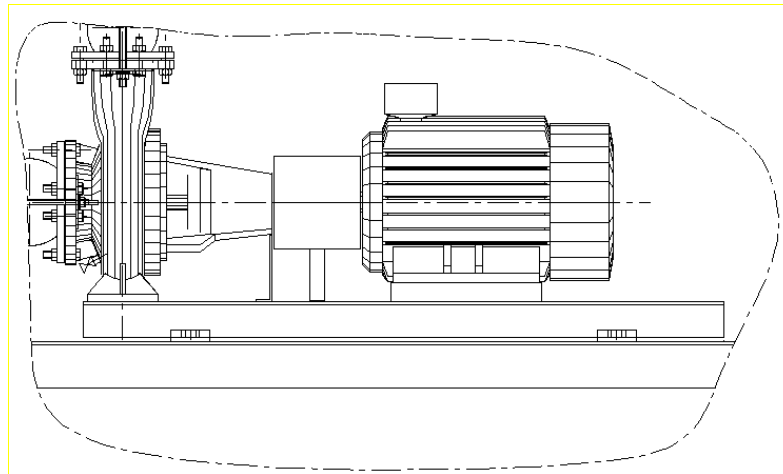

*Example Y filter*

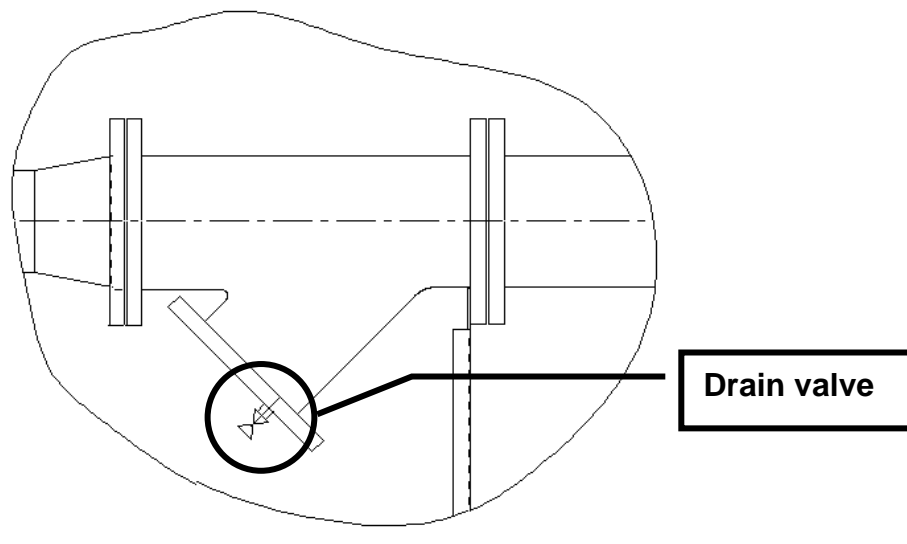

*Example of a connection at right angle of the tube end*

The length of the main piping should be as short as possible after the connection to avoid a dead end pipe.

## Water Distribution Systems

Water distribution systems should be designed in a way that they can drain when the water supply is stopped.

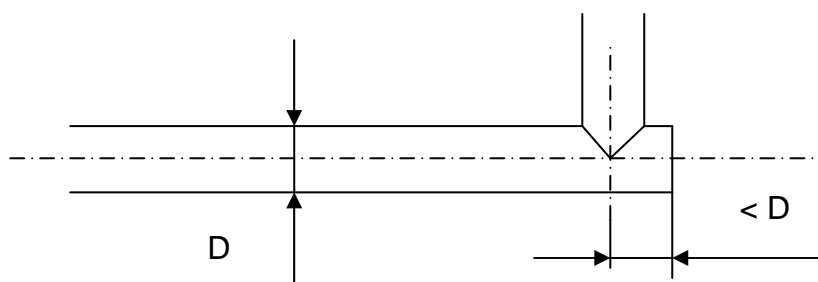

## Equalising Lines

For multiple cell installations, which do not have a common cold water basin, equalising lines may be required between the cold water basins of the individual cells. Equalising lines must be equipped with sufficient shut off valves so that the individual basins can be isolated. Furthermore, the equalising lines should have a drain and whenever possible the blow-down of the installation should be installed in the equalising line to ensure a regular water flow through the piping. Equalising lines for multiple cell closed-circuit wet cooling tower installations are not recommended and normally not needed either for this type of products.

## Water distribution:

The water distribution should be designed to be self drainable when the circulated water flow is stopped.

The water distribution shall be designed to operate at 0.5 b maximum.

In order to limit the drift emission, it is recommended the manufacturer to select water nozzles producing large size droplets, and associated to the proper efficiency of the drift eliminators.

Hence, droplet spectra which place emphasis to bigger diameters are preferred. This should be achieved by use of low-pressure nozzles or gravity driven water distributions.

There are also trickle film systems available which produce directly a water film out of the distribution header.

## Casing:

Design of casing shall secure no water stagnation. The assembly of the panels from inside shall comply with below figure.

Legend: 1 = external panel, 2 = internal panel

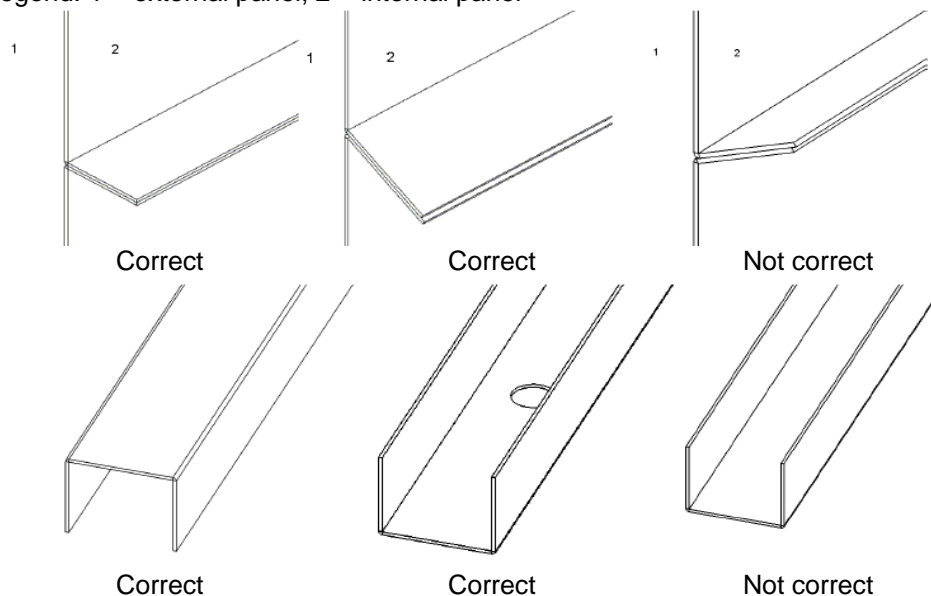

*Internal assembly of the tower's vertical panels*

## Materials of Construction

Materials used for the construction of evaporative cooling equipment should not be supporting microbiological growth (such as untreated wood or natural rubber). Internal surfaces should facilitate cleaning.

Materials of construction should have a good resistance against corrosion, such as galvanised steel, coated galvanised steel, stainless steel or organic materials such as FRP.

A part from wood, no other vegetal base component can be used. If used, wood quality shall comply with conditions:

- class of use 4 according to EN 335-2
- impregnation class 1 according to EN 350-2
- penetration class NP5 according to EN 351-1
- risk class 4 according to EN 599-1:1996 integrating field tests specified in EN 252

Wood treatment shall be made under vacuum and in pressure autoclave

### Concrete

The customer shall provide the following information to the manufacturer:

- expected life duration
- the type of reinforcement steel rods (stainless, galvanized, or black steel)
- the classification of concrete exposure as per standard EN 206-1 or EN 1992-1-1:2005 and EN 1992-1-1/ NA2007.

Lasting: the lasting shall comply with the expected operation life, particularly the cracking of the finish of the concrete surface in contact with both air and water.

Finish surface: for the finish surface in contact with both air and water, the manufacturer shall observe the roughness level in order to slow the biofilm growth and to ease the cleaning.

*Note: the cold water basin in concrete is not considered as a surface in contact with both air and water.*

### Shielding from Sunlight and other External Influences

Exposure to sunlight enhances the development of many bacteria, in particular algae.

The development of algae, which can be a nutrient for Legionella, should be avoided in evaporative cooling equipment. The casing must be as impervious as possible to sun rays.

The water basin should be shielded as much as possible from the exposure of direct sunlight, for example by the use of louvers. Such methods will also reduce the effect of wind gushes and reduce splash out from the basin, especially when the fan(s) does/do not operate. Entry of birds, vermin, leaves, debris, contaminants or other nutrients must be avoided, as much as possible.

## **6.1.3. Drift Losses and Splash out**

### Drift Losses

In all evaporative cooling systems spray water is in contact with an air stream.

Water distribution systems, using high-pressure nozzles to create droplets, are suspect for droplet spectra which contain very small droplets that may be entrained directly to the air and may also pass even sophisticated droplet separators.

Drift eliminators should cover the whole air outlet section. They should have high drift elimination efficiency. The air speed in any air outlet section shall not be higher than the breakthrough velocity of the eliminator.

The entrainment of water droplets occurs not only in the region where the water is distributed; it is also a possible effect from the surface of the falling water film on the heat exchanger surface.

The exhaust air may also contain droplets which are created by recondensation on small nuclei in the air and water droplets which are condensed on structure parts of the cooling tower, which are downstream of the droplet separator, e.g. fan support beams. Drift loss should be determined downstream of the droplet separator.

Since the chemical content of drifted droplets is the same as that of the circulating water, long term exposure of nearby structures or surroundings to the droplets can have a degenerative or aggravating effect in particular in areas of limited rainfall.

To minimize drift, eliminators, based on several techniques and application methods are operated in such "open" systems.

### Drift Eliminators

The function of the drift eliminator is to catch the droplets which are being carried away in the leaving air stream.

Working method and aerodynamic design will have important effects on this function.

By creating multiple changes in the direction of the exhaust airflow, centrifugal forces are exerted to the droplets which are carried by the air. Through inertial impaction and direct interception, entrained droplets are stripped from the leaving air stream with a minimum pressure drop.

### Corrugated Blade

Blades cut out of corrugated sheet material are connected by spacers to panels which are arranged above the water distribution means; or in cross-flow cooling towers in the entrance of the plenum chamber in front of the fan. The corrugated profile admitted a higher air velocity at an acceptable pressure drop. Different dimensions for the spacer make it possible "panels" can have handy dimensions and the shape of the profile makes a non-interrupted joint between the panels possible.

Materials used for these devices are generally fibre cement plates or plastic or FRP.

### Special Shaped Profiles

The modern drift eliminator modules are specially designed utilizing a series of sinusoidal-shaped blades. In this generation of drift eliminator modules too, the space between the shaped blades is varied for various air velocity designs. Furtheron, additional restrictions on each blade are possible to maximize capture entrained water droplets. The efficiency is relatively high in comparison with the pressure drop. Materials used to these panels are mostly plastics like PVC and PP. The self-supporting profiles are produced by extruding and combined by spacers or thermo formed film-modules with integrated spacers, glued or welded to handy panels.

## Modular Drift Eliminator

This category of drift eliminators is comparable with the shaped profile drift eliminator however figurate in length and width direction. In this way, the surface of the drift eliminator is divided into many air passage canals. The walls of these canals can have a sinusoidal shape or a kind of serpentine arrangement, sometimes combined with other obstructions to increase the separating efficiency.

The efficiency is very high related to an acceptable pressure drop. Materials used to the modular drift eliminators are thermo plastics like PVC and PP, thermo formed or injection moulded, glued or welded to handy panels.

## Conclusions

For evaporative cooling equipment requiring drift eliminators, it is important to install drift eliminators with high efficiency. Eliminators should cover the full area of the air movement. The velocity of the air moved through the eliminator must not exceed the maximum velocity suitable for a particular design. Exceeding the maximum velocity will result in the air sheering the droplets out of the eliminator. Typical air velocities range from 3.5 to 6.0 m/s. The eliminators should be accessible for regular inspections and readily removable for cleaning or replacement. Drift eliminators must be installed so that the collected water droplets can drain back into the cooling tower. With modern drift eliminators and a good cooling tower design the opportunity to minimize the phenomenon described as drift.

The selection of the appropriate drift eliminator in combination with the proper installation makes it possible to achieve drift losses less than 0.01 % of the circulating water-flow.

## Splash Out

Under certain weather and operating conditions it is possible that water splashes out of a cooling tower. Splash droplets usually are thick and hence fall out in the vicinity of the equipment. These droplets cannot easily be inhaled due to their size and the locations where they generally fall out and hence are of lower concern, when evaluating the risk of Legionella proliferation. Nevertheless, splash out should be avoided, when and where possible. Depending on the design of the product, louvers, inlet air eliminators or windwalls can be used for that purpose.

Also, operation with water pump on and fan motor(s) off should be avoided whenever and wherever possible; in this operation mode splash out is usually more eminent.

### **6.1.4. Accessory Design Recommendations (optional)**

Accessories installed in the discharge air of evaporative cooling equipment may be exposed to drift and because of this reason they must be designed in a way that they can be inspected and, if necessary be cleaned and disinfected. Typical discharge accessories are:

- sound attenuator baffles with hydrophobic filling and UV resistance ; their frame, if any, should have corrosion protection, be strong and removable for inspection and cleaning. It is recommended having a mechanical protection of the air outlet attenuator baffles.
- plume abatement coils (which should not prevent access to drift eliminators and water distribution)

- dampers or a combination thereof (which should not prevent access to drift eliminators and water distribution)
- fan screens or other
- fans mechanical protection designed so they do not allow accumulation of water.

These discharge accessories must be designed in a way that they do not obstruct the access to the interior of the equipment itself. Furthermore, access provisions must be made to allow inspections and (where necessary) maintenance and (when necessary) cleaning and disinfection. Baffles should preferably be equipped with external protection, such as perforated steel plates which also increases mechanical stability during handling and reduces the exposure to sunlight radiation. The preferred design approach is however to allow cleaning and disinfecting “in situ” without the need to remove certain components. Supporting L or U flanges should be arranged so that water cannot accumulate on them. If U channels must be installed with the U flanges showing upwards, the channels must have drain holes.

### **6.1.5. System Design Recommendations**

#### General Requirements

It is recommended to draw up a risk analysis for the cooling system in order to assess the consequences that may arise from contamination with Legionella and how to avoid the risk. The risk analysis must address the location of the cooling tower in relation to the susceptibility of the surrounding, i.e. industrial estate with restricted access, unrestricted area with low population, residential area, sensitive area (for example hospital) etc. Also, the prevailing wind direction and the distance to the “critical neighbours” must be accounted for. In general, cooling towers should be located as far as possible from open windows or air intakes to buildings.

For the cooling system an operating plan should also be developed. This plan should include a description of all system components, their technical specifications and operating limits, as well as a description of their functionality within the cooling system and the anticipated control philosophy. Both risk assessment and operating plan should be available before system start up, preferably in the system design stage.

It is imperative that a cooling system has a suitable biocide treatment with automatic or continuous operation. The biocide treatment must be set up before system start up, initiated with start up and maintained continuously thereafter.

A water treatment programme specifically designed to address scale and corrosion of the re-circulating water must be implemented when the cooling system is first operated and continuously maintained thereafter.

A user logbook, in which all relevant maintenance and repair actions, test results and events are noted, should be available at the time of system start up. The logbook should also contain a list of system components and their source, the maintenance procedures recommended by the supplier as well as the operating limits of these components. It is also recommended that the logbook contains the list of people who are authorised to access the site and conduct maintenance and/or repair work and, when applicable a list of subcontractors with authorised access.

Table 1: System Requirements

| Type of Requirement  | Time of Activity   |
|--|--|
| Cooling system risk analysis to assess the risk of Legionnaires' Disease   | Before system start-up   |
| Operating plan including water treatment and maintenance to avoid the risk   | Before system start-up   |
| Installation of suitable biocide treatment with automatic or continuous operation  | Before system start-up and maintained continuously thereafter  |
| Installation of a water treatment system to control scale and corrosion as necessary depending on the supply water quality | Before system start-up and maintained continuously thereafter  |
| Logbook to record service and maintenance activities   | Before system start-up and updated regularly (weekly or monthly)   |
| System cleaning and disinfection   | Before start up, annually or after a shut down period longer than one month or at the earliest possible shut down, when it is not possible to stop the installation easily |

### 6.1.6. Specific System Requirements

The evaporative cooling product should be installed in a way that access is maintained to the access doors provided with the equipment and other critical maintenance and inspection points, such as water distribution system and drift eliminators.

Connected pipework should be designed without dead legs and areas where stagnant layers of water may occur. The pipework should be foreseen with sufficient drain connections to allow proper drainage.

In general, the extent of external pipework should be limited as much as possible. The lesser the extent of the pipework, the easier it is to keep it clean.

Heat exchangers integrated in the cooling system should be accessible for inspections and cleaning. If heat exchangers cannot be dismantled provisions must be made to allow chemical cleaning and disinfection. It must also be possible to properly drain the heat exchangers, where needed, special drain connections must be foreseen.

All materials of construction must be compatible with each other to avoid galvanic corrosion. The corrosion resistance of the materials used must be in line with the anticipated quality of the water.

## 6.2. Operational Recommendations

The responsible operator must assure at all times that the equipment is operated within the range of conditions provided by the equipment manufacturer.

### 6.2.1. Mechanical Maintenance

A specific maintenance programme needs to be established and then monitored to ensure that the required actions are taken. This means that maintenance tasks are properly scheduled, carried out and records kept. The procedures outlined below will help to establish this programme for the cooling equipment.

## Recommended Schedule

*Table 2: Typical Mechanical Maintenance Schedule*

| Description of Service  | Start-up* | Monthly | Every 6 months | Shut-down | Annually |
|---|-----------|---------|----------------|-----------|----------|
| Inspect general condition of the system   | X         |         |                | X         | X        |
| Inspect heat transfer section(s) for fouling & scaling                            | X         |         | X              |           |          |
| Inspect water distribution  | X         |         | X              |           |          |
| Inspect drift eliminators for cleanliness and proper installation (if applicable) | X         |         | X              |           |          |
| Inspect basin (if applicable)   | X         |         | X              |           |          |
| Check and adjust basin water level and make-up (if applicable)                    | X         |         | X              |           |          |
| Check water treatment   | X         | X       |                |           |          |
| Check proper functioning of blow-down (if app.)                                   | X         | X       |                |           |          |
| Check operation of basin heaters (if applicable)                                  | X         |         | X              |           |          |
| Clean basin and basin strainer (if applicable)                                    | X         |         | X              |           |          |
| Drain basin (if applicable) and piping  |           |         |                | X         |          |

\* Initial start-up and after seasonal shut-down period.

*Note: Refer to manufacturer's instructions for detailed description of maintenance procedures.*

### Maintenance Procedures

Inspect General Condition of the System. The inspection should focus on the following areas:

- Damage to protective finishes (if applicable)
- Signs of corrosion
- Evidence of scaling
- Accumulation of dirt and debris
- Presence of biofilms

Listed below are the actions to be taken if any of the above are found during inspection:

*Table 3: Actions to be taken after inspection*

|  |   |
|--|---|
| Small damage to protective finishes (scratches, pin holes, small blisters) | Repair, following instructions of the manufacturer  |
| Large areas of damage to protective finishes                               | Consult manufacturer for repair recommendations. Check the water treatment programme and records. Make analysis of <b>re-circulating</b> water quality and compare against recommended control guidelines.  |
| Signs of corrosion   | The same procedure as above   |
| Evidence of scale  | Hardness of <b>re-circulating</b> water is too high. This could be the result of:<br>- inadequate blow-down<br>- malfunction of softener or water treatment<br>In case of local or soft scale formation; try mechanical removal.<br>If there is significant scale formation throughout the equipment, chemical cleaning is needed. Contact the manufacturer or competent water treatment company for recommendations. |
| Accumulation of dirt and debris:   | Clean out dirt and debris. If necessary system should be drained and filled with fresh water. At start up apply biocide shock treatment.  |
| Presence of biofilms:  | If there is evidence of biofilms, the system, including piping, should be drained, flushed and cleaned of slimes, algae and other organic contamination. Refill with clean water and apply initial biocide shock treatment. Check pH value and ongoing biocide treatment.   |

### Inspect Heat Transfer Section(s) for Fouling & Scaling

Minor fouling can usually be removed chemically or by temporary changes to the water treatment programme. Contact a water treatment supplier for advice. Major fouling and scaling requires cleaning and flushing or even the replacement, thereafter replenishment with fresh water and a review of the effectiveness of the water treatment. In severe cases, it may be necessary to remove the heat exchanger.

### Inspect Water Distribution

The water distribution system should be free of dirt and debris. All nozzles, troughs etc. need to be in place and clean. In case of contamination, clean the water distribution system as per manufacturer's instructions. Replace damaged or missing nozzles, as well as any nozzles which cannot be cleaned.

### Inspect Drift Eliminators (if applicable)

Drift eliminators must be inspected from both sides unless they are integrated in the fill pack, in which case only one side can be inspected. Drift eliminators must be clear of debris and any foreign matter. Remove any dirt or obstructions. Damaged or inefficient eliminators must be replaced with qualified ones. Eliminators should fit tightly with no gaps.

### Inspect Basin (if applicable)

The cleanliness of the basin is a good guide to the overall condition of the cooling system. In the case of larger basins (usually concrete) regular cleaning and flushing may not be practical. If not already done take water samples and check the aerobic bacteria count. If this is above the recommended level, apply biocide shock treatment or temporarily adjust biocide treatment until required values are maintained.

### Check and Adjust Basin Water Level and Make-up (if applicable)

Set basin water level in accordance with the manufacturer's recommendation. Check functional operation of the make-up system and adjust settings as per manufacturer's requirements. Replace any worn or damaged components in the water level control and make-up assemblies.

### Check Chemical Feed Equipment

Check that the chemical feed equipment has power and that it is functioning normally. It is recommended that a more detailed check be carried out on a regular basis by the water treatment service provider.

### Check Proper Functioning of Blow-down

In the case of continuous blow-down with a metering valve in the bleed line, ensure that the valve is unobstructed and that blow-down water can drain freely. Measure the blow-down flow rate by recording the time needed to fill a given volume.

For automatic blow-down using conductivity control, ensure that the conductivity probe is clean and that the blow-down solenoid valve is operational. Unless there is a specific set point adjustment procedure, the water treatment company should check and adjust set points.

### Check Operation of Basin Heaters (if applicable)

Basin heaters must only operate in winter to prevent the basin water from freezing. Under no circumstances should basin heaters operate at other times as they could potentially heat the water to temperature levels, which are favourable for bacteriological growth. Ensure that the heater thermostat is properly set and clean. Also ensure that heater control and safety devices, such as low-level cut-out switches, are operational and properly incorporated into the control circuit.

### Clean Basin Strainer (if applicable)

Remove the strainer from the basin. Clean mechanically or with a high pressure hose. Replace if damaged or corroded. Re-install as per manufacturer's instructions.

### Drain Basin (if applicable) and Piping

During a prolonged shutdown it is recommended to drain the basin and the associated piping. Ensure that the drain remains open, so rain water or melting snow can drain from the basin. Also ensure that all piping exposed to freezing conditions is drained; if not, this piping has to be insulated and heat-traced. Piping that will not be drained should be valved off to avoid contact with the atmosphere. Shut off the make-up water supply.

### Qualification of Personnel

The operation, maintenance and repair of equipment incorporated into the evaporative cooling loop and including water treatment components and controls should be undertaken only by personnel authorised and qualified to do so. All such personnel should be thoroughly familiar with the equipment, the associated systems and controls and the operating and maintenance instructions submitted by the component suppliers as well as the operating plan for the system. Proper care, procedures and tools must be used in handling, operating and repairing the above mentioned equipment to prevent personal injury and/or property damage. It is recommended to keep a list of authorised personnel in the system logbook.

### Skill Required

The minimum qualification of people to use and maintain cooling towers is as follows:

1. capable to read drawings and tower manufacturer's instructions for use and maintenance.
2. to be instructed about:
  - the health and safety regulation into force on site and in the country.
  - the risk analysis into force on the site.
  - Legionella disease (protection, prevention, symptoms)
  - cooling tower function and driving (make-up, blow down, energy contamination, etc... what is possible to be done and what is strictly forbidden by manufacturer)
  - notion of water treatments and of water treatments diagnosis
  - what it is to survey: drift eliminators, fouling, scaling etc...
  - cleaning and disinfection operation and programs
  - maintenance of electrical and mechanical equipment

## 6.2.2. Water Quality

The Table 4 below indicates typical recommended control parameters and their required values to control biological growth and scale formation. Maximum values for rates of corrosion should be stipulated by the system designer and verified by the water treatment specialist.

Table 4: Water Quality

| Type of Parameter   | Recommended Face Value   |
|---|--|
| Total aerobic bacteria (TAB)                                    | Not exceeding 10.000 cfu/ml  |
| Legionella  | Not exceeding 1000 cfu/litre   |
| pH value  | between 7 and 9  |
| Hardness of recirculating water                                 | < 36°F<br>< 20°d<br>< 360 mg/l as CaCO <sub>3</sub>                        |
| Other parameters, such as chlorides, sulphates and conductivity | As per system specification or water treatment specialist recommendations. |

### Recommended Monitoring Schedule

The quality of the water may vary during operation. Diagnose of a problem based on a single water analysis is usually not possible. For this reason it is important that water samples are regularly taken and that the analysis of these water samples is kept on record.

A well functioning water treatment system significantly reduces the need for cleaning and disinfection. Monitoring the microbiological concentration below the face values vastly helps preventing biological contamination. The table below summarises the recommended monitoring scheme.

Table 5: Typical Water Quality Monitoring Schedule

| Control Activity  | Time of Execution  |
|---|--|
| Check operation of water treatment system                       | Initial start-up and after seasonal shutdown period. Thereafter monthly.                       |
| Check stock of chemicals  | Initial start-up and after seasonal shutdown period. Thereafter weekly.                        |
| Monitor TAB concentration                                       | Weekly   |
| Monitor re-circulating water quality against Control Parameters | Monthly  |
| Visual inspection for algae, biofilm formation                  | Every 6 months   |
| Check LS concentration  | If TAB remains high (see Table 5) after corrective action or if LS contamination is suspected. |

### Water Quality Control Procedures

**Check Operation of Water Treatment System:** It is imperative that proper water treatment is in operation at start-up and continuously operated and maintained thereafter.

**Check Stocks of Chemicals:** It is important not to run out of chemicals and arrangements should be made to replenish stocks of chemicals well before they are exhausted.

**Monitor Total Aerobic Bacteria (TAB) Concentration:** There are various methods to determine the total aerobic bacteria concentration. The use of dip slides is a recommended practice. For evaporative cooling equipment the following control levels should be observed.

Table 6: TAB Concentration Corrective Action Levels

| TAB concentration in cfu/ml | Recommended Action   |
|-----------------------------|--|
| < 10.000                    | No action required   |
| Between 10.000 and 100.000  | Repeat test and if high TAB concentration is confirmed increase biocide treatment. If high TAB persists carry out LS test. If LS concentration at 1000 cfu/litre or above is confirmed, clean and disinfect the system. Repeat test every two weeks until LS concentration remains below 100 cfu/l |
| > 100.000                   | Immediate cleaning and disinfection is required.   |

*Monitor re-circulating Water Quality against Control Parameters:*

\**Check Make-up Water Quality date:* Usually 1 litre of sample water is sufficient. The analysis must be made within a few days after the sample has been taken. As a minimum the following parameters need to be checked:

- pH
- total hardness
- alkalinity
- chlorides
- sulphates
- conductivity

Compare the analysis with previous records or, in the case of a first sample at start-up, with the water data used to choose the water treatment system. If results deviate from design data or previous data, it is recommended to analyse three more samples taken in successive weeks. Based on the results, find the cause of varying make-up water quality with the assistance of a water treatment specialist and adjust the water treatment programme accordingly.

*Note:* Where the make-up water quality is variable, it is recommended to install a conductivity controlled blow-down system. In addition more care needs to be taken in monitoring the chemical water treatment. Consult a competent water treatment company for advice.

\* *Check Circulating Water Quality against Guidelines:* Follow the same procedure as the make-up water except for the location of sample taking. Usually the basin is the best place to take circulating water samples. Make sure the sample is not taken in an area influenced by any make-up water or chemical dosage. Do not take samples shortly after cleaning and/or refilling operations – allow minimum 3 days of operation under significant load before a sample is taken. Other locations such as the blow-down line can also be considered for sample taking.

In the case of installations with filtration do not use back flush water from the filter for sample taking.

Compare the results with the water quality control parameters for the system. If any of the given limits are exceeded significantly, immediate action is required. In many cases an increase of the blow-down will provide a satisfactory solution. It is however recommended to consult a reputable water treatment specialist. Where the limits are slightly exceeded, compare results with previous records and look for trends. If these show increased or persistent deviations, adjustments to the water treatment programme may be needed. It is recommended to temporarily increase the sample taking to one sample per week for three weeks. If these samples are within limits, no action is required. If not, adjustment to the water treatment programme is needed.

*Visual Inspection for Algae, Biofilm Formation:* If the recommended maximum levels for TAB concentration are not exceeded and corrective action (if required) is taken in good time, it is unlikely that biofilms will develop within the system. Nevertheless it is recommended to visually inspect the system for biofilm every six months. Since a visual inspection of ALL system internals is generally not possible, it is sufficient to inspect the “critical” areas, i.e. these areas where biofilms are likely to develop first. The top and bottom of the fill pack, drift eliminators and basins, as well as areas where the water may be stagnant during shutdown, are the most “critical” areas. If biofilm formation is noted, it is necessary to clean and disinfect the system (see below). It is also recommended to conduct a functional check of the biocide treatment, as the formation of biofilm may be a result of system malfunction.

*Check LS Concentration:* Unless specified by local regulations, it is not normally necessary to test for Legionella concentration in the re-circulating water. If however contamination with Legionella is suspected, a test should be carried out by an accredited laboratory.

Depending on the results of the Legionella test, the actions listed in Table 7 will apply.

*Table 7: Legionella specie Concentration and Corrective Measures*

| <b>Legionella concentration in cfu/litre</b> | <b>Corrective Action</b>                      |
|--|---|
| Less than 100                                | No action required                            |
| Between 100 and 1000                         | Adjust biocide treatment                      |
| Between 1000 and 10000                       | Corrective action                             |
| Larger than 10000                            | Immediate disinfection, cleaning if necessary |

### System Cleaning and Disinfection

#### a) Cleaning

It is important that the cooling system is cleaned prior to initial start-up or before being put back into service after a prolonged shutdown.

It is also recommended that the cooling system is drained and cleaned annually. In heavily industrialised areas or if the re-circulating water is contaminated this may be needed more often. Where high aerobic bacteria count is suspected or is a re-occurring problem the system should be disinfected as described below PRIOR to the cleaning operation.

Once the system is drained an inspection of all the internal surfaces will indicate the extent of physical cleaning needed. All silt, sludge and debris should be removed from the basin. Where the fill pack is heavily fouled or contaminated it should also be cleaned or replaced. The water distribution system and drift eliminators should be thoroughly cleaned and inspected for damage or missing parts.

Sound attenuators or other accessories that show signs of contamination will also require cleaning.

After cleaning, the system should be flushed thoroughly and re-filled with fresh water. Before putting the equipment back into service the appropriate start-up level of treatment chemicals especially biocidal treatment must be added.

#### b) Disinfection

Disinfection must be carried out in accordance with a proper procedure and taking into account the safety of the cleaning and disinfection staff.

Typically, disinfection is achieved using sodium hypochlorite solution to maintain a residual value of 5 – 15 mg/l of the free chlorine.

It is necessary to consult specialised personnel and possibly the suppliers of the system components. Chlorinated water should be de-chlorinated before draining and after disinfection the system must be thoroughly flushed through with clean water.

### **6.2.3. Monitoring and Record Keeping**

In order to be able to monitor the efficient and safe operation of the cooling system all maintenance and water quality monitoring actions should be recorded in a cooling system logbook.

If a specialist maintenance contractor or water treatment company is servicing the cooling system, copies of their visit reports and service actions should also be reviewed carefully and filed in the logbook.

As a minimum the following records should be kept:

- Commissioning and initial start-up reports
- Monthly, six monthly and annual mechanical maintenance actions
- Seasonal shutdown and start-up actions
- Monthly and annual water quality monitoring actions
- Monthly water treatment service reports
- Weekly TAB test result
- Cleaning and disinfection actions
- Cooling system problems and corrective action taken.

## **7. Personal Safety**

The health and safety of both employees and other people not connected with the work activity but who are in the vicinity of the installation, must be protected. Please ensure that all personnel working on the cooling water system have taken the following precautions:

Fans, pumps, heaters etc. are electrically isolated before commencing any inspection or maintenance work.

Normal protective clothing is adequate for all internal inspection and cleaning operations. However, note requirement for half face respirator masks when working on equipment that may be contaminated.

### **Personal Protection**

Maintenance or cleaning personnel working on equipment that may be contaminated should wear half face respirator masks of P3 or equivalent type or better.

This precaution is needed:

- if stagnant or contaminated water has not been drained off
- if adjacent cells are still operating
- when cleaning with a high pressure jet
- if a high LS concentration has been measured.

## **Annex: Typical contents of cooling system logbook**

### **Section 1: Owner Information**

1. Name and address of plant owner
2. Responsible plant manager/engineer
3. System operator(s)
4. Person(s) in charge of maintenance.

### **Section 2: System Components**

1. Supplier/type of cooling tower or evaporative condenser, serial number, cooling system reference number
2. Supplier/type of biocide treatment, description and reference numbers of components/chemicals
3. Supplier/type of water treatment, description and reference numbers of components/chemicals
4. Supplier/type of auxiliary equipment [pump(s), heat exchanger(s), filter(s), other] and serial numbers of components
5. Suppliers' technical data sheets and/or catalogues.
6. Operating limits (temperatures / pressure/water quality etc.).

### **Section 3: Subcontractors / Service Providers**

Full address and contact details of subcontractors/service providers and names of people admitted to site.

### **Section 4: Risk Analysis**

Cooling system risk analysis, if available

### **Section 5: Operating and Maintenance Plan**

Operating plan (description of cooling system and water treatment, control sequence, shut-down periods etc.)

Mechanical maintenance schedule (see Attachment A)

Suppliers' operating and maintenance literature

### **Section 6: Data Logging and Record Keeping**

TAB testing and results (see Attachment B)

Water quality monitoring and results (see Attachment C)

Event record keeping (see Attachment D)

## Section 7: Safety

- Location of cooling tower(s) (if not already in risk analysis)
- Personal safety instructions for mechanical maintenance
- Personal safety instructions for water treatment system
- Safety data sheets for all chemicals
- Personal safety instructions for auxiliary components.

## Section 8: Reports

Insert all relevant reports (commissioning reports, certificates, training records etc.).

## Attachment A: Typical Recommended Maintenance Schedule for Cooling Towers and Evaporative Condensers

| Description of Service                                | Start-up or after shut-down | Weekly | Monthly | Every 6 months | Annually |
|---|-----------------------------|--------|---------|----------------|----------|
| <i>Inspect general condition of unit</i>              |                             |        |         |                |          |
| <i>Check debris from unit</i>                         |                             |        |         |                |          |
| <i>Inspect basin – clean and Flush if required</i>    |                             |        |         |                |          |
| <i>Clean basin strainer</i>                           |                             |        |         |                |          |
| <i>Check and adjust basin water level and make-up</i> |                             |        |         |                |          |
| <i>Inspect heat transfer section(s)for fouling</i>    |                             |        |         |                |          |
| <i>Inspect water distribution</i>                     |                             |        |         |                |          |
| <i>Check drift eliminators</i>                        |                             |        |         |                |          |
| <i>Check water quality against guidelines</i>         |                             |        |         |                |          |
| <i>Check chemical feed equipment</i>                  |                             |        |         |                |          |
| <i>Check and adjust bleed rate</i>                    |                             |        |         |                |          |
| <i>Check pan heaters and accessories</i>              |                             |        |         |                |          |
| <i>Drain basin and piping</i>                         |                             |        |         |                |          |
| <i>Inspect protective finishes</i>                    |                             |        |         |                |          |
| <i>Check fans for rotation without obstruction</i>    |                             |        |         |                |          |
| <i>Check fan and pump motors for proper rotation</i>  |                             |        |         |                |          |
| <i>Check unit for unusual noise/vibration</i>         |                             |        |         |                |          |
| <i>Check motor(s) voltage and current</i>             |                             |        |         |                |          |
| <i>Lubricate fan shaft bearings</i>                   |                             |        |         |                |          |
| <i>Check and service fan drive system</i>             |                             |        |         |                |          |

# Attachment B: Tab Testing and Results

| Week | Date Sample Taken | TAB Concentration cfu/ml | Remarks | Signature of Tester |
|------|-------------------|--------------------------|---------|---------------------|
| 1    |                   |                          |         |                     |
| 2    |                   |                          |         |                     |
| 3    |                   |                          |         |                     |
| 4    |                   |                          |         |                     |
| 5    |                   |                          |         |                     |
| 6    |                   |                          |         |                     |
| 7    |                   |                          |         |                     |
| 8    |                   |                          |         |                     |
| 9    |                   |                          |         |                     |
| 10   |                   |                          |         |                     |
| 11   |                   |                          |         |                     |
| 12   |                   |                          |         |                     |
| 13   |                   |                          |         |                     |
| 14   |                   |                          |         |                     |
| 15   |                   |                          |         |                     |
| 16   |                   |                          |         |                     |
| 17   |                   |                          |         |                     |
| 18   |                   |                          |         |                     |
| 19   |                   |                          |         |                     |
| 20   |                   |                          |         |                     |
| 21   |                   |                          |         |                     |
| 22   |                   |                          |         |                     |
| 23   |                   |                          |         |                     |
| 24   |                   |                          |         |                     |
| 25   |                   |                          |         |                     |
| 26   |                   |                          |         |                     |
| 27   |                   |                          |         |                     |
| 28   |                   |                          |         |                     |
| 29   |                   |                          |         |                     |
| 30   |                   |                          |         |                     |
| 31   |                   |                          |         |                     |
| 32   |                   |                          |         |                     |
| 33   |                   |                          |         |                     |
| 34   |                   |                          |         |                     |
| 35   |                   |                          |         |                     |
| 36   |                   |                          |         |                     |
| 37   |                   |                          |         |                     |
| 38   |                   |                          |         |                     |
| 39   |                   |                          |         |                     |
| 40   |                   |                          |         |                     |
| 41   |                   |                          |         |                     |
| 42   |                   |                          |         |                     |
| 43   |                   |                          |         |                     |
| 44   |                   |                          |         |                     |
| 45   |                   |                          |         |                     |
| 46   |                   |                          |         |                     |
| 47   |                   |                          |         |                     |
| 48   |                   |                          |         |                     |
| 49   |                   |                          |         |                     |
| 50   |                   |                          |         |                     |
| 51   |                   |                          |         |                     |
| 52   |                   |                          |         |                     |

## Attachment C: Typical Quality Monitoring Checks

### A. Make-up Water

| Parameter      | Control value | Jan. | Feb. | March | Apr. | May | June | July | Aug. | Sept. | Oct. | Nov. | Dec. |
|----------------|---------------|------|------|-------|------|-----|------|------|------|-------|------|------|------|
| pH             |               |      |      |       |      |     |      |      |      |       |      |      |      |
| Total hardness |               |      |      |       |      |     |      |      |      |       |      |      |      |
| Alkalinity     |               |      |      |       |      |     |      |      |      |       |      |      |      |
| Chlorides      |               |      |      |       |      |     |      |      |      |       |      |      |      |
| Sulphates      |               |      |      |       |      |     |      |      |      |       |      |      |      |
| Conductivity   |               |      |      |       |      |     |      |      |      |       |      |      |      |
| Remarks        |               |      |      |       |      |     |      |      |      |       |      |      |      |
| Signature      |               |      |      |       |      |     |      |      |      |       |      |      |      |

### B. Re-irculating Water

| Parameter      | Control Value | Jan. | Feb. | March | Apr. | May | June | July | Aug. | Sept. | Oct. | Nov. | Dec. |
|----------------|---------------|------|------|-------|------|-----|------|------|------|-------|------|------|------|
| pH             |               |      |      |       |      |     |      |      |      |       |      |      |      |
| Total hardness |               |      |      |       |      |     |      |      |      |       |      |      |      |
| Alkalinity     |               |      |      |       |      |     |      |      |      |       |      |      |      |
| Chlorides      |               |      |      |       |      |     |      |      |      |       |      |      |      |
| Sulphates      |               |      |      |       |      |     |      |      |      |       |      |      |      |
| Conductivity   |               |      |      |       |      |     |      |      |      |       |      |      |      |
| Remarks        |               |      |      |       |      |     |      |      |      |       |      |      |      |
| Signature      |               |      |      |       |      |     |      |      |      |       |      |      |      |

## Attachment D: Event Record Keeping

| <b>Type of Event<br/>(Inspection/Maintenance/<br/>Cleaning/Disinfection)</b> | <b>Date of<br/>Event</b> | <b>Remarks</b> | <b>Signature</b> |
|--|--------------------------|----------------|------------------|
|  |                          |                |                  |
|  |                          |                |                  |
|  |                          |                |                  |
|  |                          |                |                  |
|  |                          |                |                  |
|  |                          |                |                  |
|  |                          |                |                  |
|  |                          |                |                  |
|  |                          |                |                  |